

Precision Hydrogen SL (All Models)

User Manual

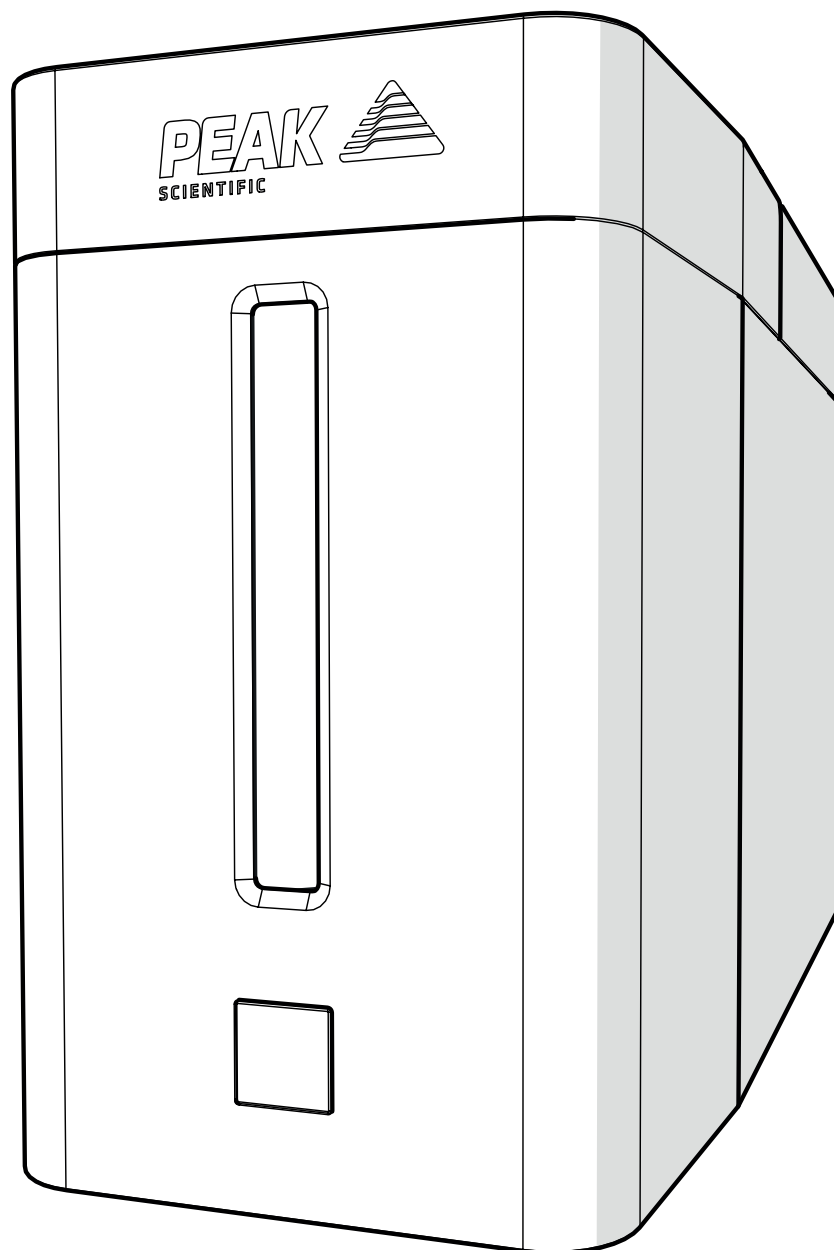

Contents

Change History	3
How to use this Manual	3
Safety Notices	4
Attention - Important Notice to All Users	5
General Safety	6
Generator Safety Features	6
Health and Safety Data	7
De-ionizer Resin	7
Desiccant	9
Molecular Sieve	11
EU Declaration of Conformity	13
UK Declaration of Conformity	14
CSA Compliance Statement	15
WEEE Compliance Statement	16
Warranties and Liabilities	17
Technical Specification	18
Introduction	19
Principle of Operation	20
Unpacking	21
Fittings Kit Contents	22
Installation	23
Location	23
Generator Overview	24
General Dimensions	24
Unit Controls	25
Rear Connections	25
Tubing	26
H2 Ventilation	26
Water Quality	26
Manual Water Tank Filling	27
Automatic Filling (Automatic Fill Upgrade units only)	28
Pressurized Filling (Automatic Fill Upgrade units only)	29
Inline Water Filter Cleaning (Automatic Fill Upgrade units only)	29
Water Usage	30
Electrical Connection	31
Start-up Sequence	32
Liquid Leak Detectors	32
Gas Traps	32
Switching the Unit Off	33
Cleaning	33
De-ionizer cartridge Replacement	34
Replacement of Desiccant Capsule	35
Service Requirements	37
Service Schedule	37
Service Plans	37
General Troubleshooting	38
Overview of LED Colour States	38
Debugging by LED	39

Change History

Rev	Comment	Name	Date
1	Initial Release	L. Couttie	10/04/2020
2	Product Updates	L. Couttie	20/01/2021
3	Product Updates	L. Couttie	10/03/2021
4	Product Updates	L. Couttie	26/03/2021
5	Flow Rate Update	C Denholm	07/10/2021
6	Declarations Update	L. Couttie	13/12/2021

How to use this Manual

This manual is intended for end users and has been written so that it can either be read as a step by step guide to installation and usage or as a reference document where you can skip to the relevant information.

Users of a hard copy version can refer to the contents page to find the relevant information. Users of the soft copy version can use the hyperlinks from the contents page as well as the hyperlinks between sections.

Please review each of the following sections carefully.



Thank you for selecting Peak Scientific to meet your gas generation needs, and should you require any further assistance or support please do not hesitate to contact Peak Scientific or the Peak Partner from which you purchased your Generator.

Safety Notices

Peak Scientific Instruments cannot anticipate every possible circumstance which may represent a potential hazard. The warnings detailed within this manual refer to the most likely potential hazards, but by definition cannot be all inclusive. If the user employs an operating procedure, item of equipment or a method of working which is not specifically recommended by Peak Scientific, the user must ensure that the equipment will not be damaged or become hazardous to persons or property.

Symbols

This manual uses the following symbols to highlight specific areas important to the safe and proper use of the Generator

 WARNING	A WARNING notice denotes a hazard. It calls attention to an operating procedure, process or similar, which if not correctly performed or adhered to, could cause personal injury or in the worst case death. Do not proceed beyond a WARNING notice until the indicated conditions are fully understood or met.
 CAUTION	A CAUTION notice denotes a hazard. It calls attention to an operating procedure, process or similar, which if not correctly performed or adhered to, could cause damage to the generator or the application. Do not proceed beyond a CAUTION notice until the indicated conditions are fully understood or met.
	Caution, risk of electric shock. Ensure power to the generator has been removed before proceeding.

Safety Notice to Users



These instructions must be read thoroughly and understood before installation and operation of your Peak Precision Hydrogen Generator. Use of the generator in a manner not specified by Peak Scientific MAY impair the SAFETY provided by the equipment.



When handling, operating or carrying out any maintenance, personnel must employ safe engineering practices and observe all relevant local health and safety requirements and regulations. The attention of UK users is drawn to the Health and Safety at Work Act 1974, and the Institute of Electrical Engineers regulations.



If the equipment is used in a manner not specified by the manufacturer, the protection provided by the equipment may be impaired.

Attention - Important Notice to All Users



These instructions must be read thoroughly, section by section and understood before installation and operation of your Peak Scientific Hydrogen Generator. Please follow the appropriate safety standards for handling hydrogen gas and other gases as determined by the laws and regulations of your country.



Generator is for indoor use only.

Please save the product packaging for storage or future shipment of the generator.

1. For your own personal safety and to prevent accidental damage to your generator please ensure that you read and understand our User Manual.
2. Do not store away the generator when not in operation. External water bottles must be made of a dark coloured glass or Nalgene in order to prevent biological growth (available from Peak Scientific). It is recommended that you check the water quality weekly to prevent biological growth developing in the tank and tubing. Failure to do this will greatly reduce the life of the generator and render the 2 year generator warranty void.
3. If you are using a manual fill system, the tank cap must be replaced after filling the tank with water.
4. If your system requires an external tank, do not place the external water bottle above the height of the generator. The bottle may be placed at the same level or below the generator.
5. Use ASTM Type I or Type II water only. ($<1 \mu\text{S}/\text{cm}$ conductivity / $>1 \text{M}\Omega\text{-cm}$ resistivity). Failure to use the correct quality water will invalidate the cell and system warranty.
6. Failure to maintain the de-ionizer cartridge as recommended will reduce the operational life of your generator and render its 2 year generator warranty void.
7. Do not attach any additional tanks or gas cylinders to your generator without first consulting Peak Scientific.
8. Ensure your entire installation, both pipe work and analysers, are completely gas tight. Even minor leaks will affect the operation of your generator and can reduce its operational life.
9. Check that the output capacity of your generator meets the total gas requirements of your application. If in doubt, consult your dealer or Peak Scientific.
10. Ensure the ambient temperature inside your laboratory does not rise above $35^\circ\text{C}/95^\circ\text{F}$. Extremes of operating temperature will reduce cell life.

General Safety

The generator produces gas when the application places a demand on the unit. The **maximum** quantity of hydrogen stored in the generator at any one time is 175ml at a pressure of 7.6bar (110psi). The unit also meets the European Electromagnetic Compatibility and Low Voltage Directives. The Generator is CE approved and has the CE mark attached.

All of the Precision Hydrogen Series generators have the necessary control circuitry, both hardware and software, to ensure the shutdown of the instrument in the event of a fault or faults occurring.



The rear section of the generator should only be opened by trained personnel in line with maintenance instructions.

Generator Safety Features

The Precision Hydrogen range have the following safety features to ensure safe and reliable operation:

- Overpressure switch.
- Safe and accurate control of pressure.
- Internal leak detection.
- Cell shut down in critical alarm status.
- Critical water level detection.
- Internal water overflow prevention.

Health and Safety Data

De-ionizer Resin

This sheet to be retained by the 'Health & Safety Officer'

The recipient of this Health & Safety Data sheet is required to ensure that all personnel handling, using or likely to come into contact with the material are made aware of the Health & Safety information contained herein.

General Description

Cylinder containing ion exchange resin. 60% Cation and 40% Anion by mass.

Chemical Components

Polystyrene divinylbenzene cation and ion exchange resin.

Form	Solid beads
Flash Point	N/A
Colour	Tan
Ignition Temperature	427 °C (Estimated)
Odour	None
Explosion Limits	N/A
Decomposition Temperature	Over 220 °C
Vapour Pressure @ 25 °C	17mm CFH @ 20 °C (Water)
Viscosity @ 25°C	N/A
Solubility in Water	Negligible
Specific Gravity @ 25°C	1.1-1.3
pH @ 25 °C	7-9.5 in aqueous slurry
Eye Protection	Safety Glasses (BS2092C)
Storage	Store in a cool place above 0 °C, out of direct sunlight
Fire & Explosion Hazards	Toxic combustion products may include sulphur dioxide and sulphur trioxide
Disposal	This product can be disposed as ordinary waste if local regulations permit

Emergency & First Aid Procedures

Spillages

Floor may be slippery. Use care to avoid falls. Wear protective glasses.

Sweep up and transfer to containers for recovery and disposal.

Extinguishing Media

Carbon Dioxide (CO₂), Water Fog and Dry Powder.

Fire Fighting and Protection

Wear HSE approved, pressure demand, self-contained breathing apparatus or equivalent.

First Aid**Skin Contact**

Wash effected areas with soap and water. Consult doctor if irritation persists.

Eye Contact

Product can cause severe eye irritation. Flush eyes with large amounts of water for at least 15 minutes. Consult a doctor if irritation persists.

Inhalation

This product should present no hazard if operated under normal conditions. If irritation persists, move patient to fresh air.

Ingestion

If resin has been confined to the mouth, administer 250 ml. of water as a mouthwash. Avoid swallowing. This product is considered non-hazardous if ingested in small amounts; however, it is advisable to seek medical advice.

Toxicological Data

No toxicity data available on this product

Occupation exposure limits

STEL/TLV = None established.

Incompatible Materials (to avoid hazardous reactions)

Avoid contact with concentrated nitric acid and any other strong oxidising agents at all times.

Desiccant

This sheet to be retained by the 'Health & Safety Officer'

The recipient of this Health & Safety Data sheet is required to ensure that all personnel handling, using or likely to come into contact with the material are made aware of the Health & Safety information contained herein.

General Description

Column containing orange to green indicating silica gel.

Chemical Components

Amorphous silica 98.2%, activated colouring agent 0.2% max.

Form	Beads
Flash Point	N/A
Colour	Dry: yellow/orange Saturated: Green
Ignition Temperature	>1000 °C
Odour	Odourless
Explosion Limits	N/A
Decomposition Temperature	Over 155 °C
Vapour Pressure @ 25 °C	17mm CFH @ 20 °C (Water)
Viscosity @ 25°C	N/A
Solubility in Water	less 1.0% in weight
pH @ 25 °C	2-10 at 5% w/w in water
Eye Protection	Safety Glasses (BS2092C)
Storage	All containers must be closed air tight and kept in a dry place.
Fire & Explosion Hazards	N/A
Disposal	This product can be disposed as ordinary waste if local regulations permit.

Emergency & First Aid Procedures

Spillages

Contain spillage. Collect in suitable containers for recovery or disposal. During collection avoid creating dust.

Extinguishing Media

N/A. Inorganic compound. Not combustible.

Fire Fighting and Protection

Wear HSE approved, pressure demand, self-contained breathing apparatus or equivalent.

First Aid**Skin Contact**

Wash spillage from skin with soap and water.

Eye Contact

Wash immediately with copious amounts of water and obtain medical attention.

Inhalation

Remove from source of exposure.

Ingestion

Wash out mouth with water. If large amount swallowed or symptoms develop obtain medical attention.

Toxicological Data

The lethal dose for humans for synthetic amorphous silica is estimated at over 15,000 mg/kg

Occupation exposure limits

DNEL/PNEC < 1 = No immediate concern.

Incompatible Materials (to avoid hazardous reactions)

None known.

Molecular Sieve

This sheet to be retained by the 'Health & Safety Officer'

The recipient of this Health & Safety Data sheet is required to ensure that all personnel handling, using or likely to come into contact with the material are made aware of the Health & Safety information contained herein.

General Description

Column containing white to tan molecular sieve.

Chemical Components

Quartz (SiO₂) <10%, balance Zeolite.

Form	Spheres
Flash Point	N/A
Colour	White to tan
Ignition Temperature	N/A
Odour	Odourless
Explosion Limits	N/A
Decomposition Temperature	N/A
Vapour Pressure @ 25 °C	N/A
Viscosity @ 25°C	N/A
Solubility in Water	Insoluble
pH @ 25 °C	N/A
Eye Protection	Safety Glasses (BS2092C)
Storage	All containers must be closed air tight and kept in a dry place.
Fire & Explosion Hazards	N/A
Disposal	This product can be disposed as ordinary waste if local regulations permit.

Emergency & First Aid Procedures

Spillages

Contain spillage. Collect in suitable containers for recovery or disposal. During collection avoid creating dust.

Extinguishing Media

N/A. Inorganic compound. Not combustible.

Fire Fighting and Protection

Wear HSE approved, pressure demand, self-contained breathing apparatus or equivalent.

First Aid**Skin Contact**

Wash spillage from skin with soap and water.

Eye Contact

Wash immediately with copious amounts of water and obtain medical attention.

Inhalation

Remove from source of exposure.

Ingestion

Wash out mouth with water. If large amount swallowed or symptoms develop obtain medical attention.

Toxicological Data

The lethal dose for humans for synthetic amorphous silica is estimated at over 15,000 mg/kg

Occupation exposure limits

DNEL/PNEC < 1 = No immediate concern.

Incompatible Materials (to avoid hazardous reactions)

None known.

EU Declaration of Conformity

We Peak Scientific Instruments Ltd.
Of Fountain Crescent, Inchinnan, Renfrewshire, PA4 9RE

Hereby declare that, this declaration of conformity is issued under the sole responsibility of the manufacturer.

Equipment Type: Hydrogen Generator
Model Designator: Precision Hydrogen SL

To which this declaration relates, is in conformity with the following applicable EU Directives, harmonized standards, and other normative requirements.

- **Low Voltage Directive 2014/35/EU**
EN 61010-1: 2010 Safety Requirements for Electrical Equipment for Measurement, Control and Laboratory Use.
- **Electromagnetic Compatibility Directive 2014/30/EU**
EN 61326-1: 2013 Electrical Equipment for Measurement, Control and Laboratory Use - EMC Requirements. (Class A)
- **Restriction on the use of certain hazardous substances in electronic equipment (RoHS) Directive 2011/65/EU as amended by EU 2015/863.**
- **FCC 47 CFR Part 15 class A**
Unintentional radiators; Conducted and Radiated emissions limits.

Signed for and on behalf of Peak Scientific by

Signed: 

Name: Fraser Dunn

Position: Design Engineering Manager
Peak Scientific Instruments Ltd,
Inchinnan, Renfrew, Scotland, PA4 9RE, UK.

Date: 7th October 2021



UK Declaration of Conformity

We Peak Scientific Instruments Ltd.
Of Fountain Crescent, Inchinnan, Renfrewshire, PA4 9RE

Hereby declare that, this declaration of conformity is issued under the sole responsibility of the manufacturer.

Equipment Type: Hydrogen Generator
Model Designator: Precision Hydrogen SL

To which this declaration relates, is in conformity with the following applicable UK Statutory Instruments, Standards and other normative requirements.

- **The Electrical Equipment (Safety) Regulations 2016 (SI 2016 / 1101) as amended.**
BS61010-1:2010 Safety Requirements for Electrical Equipment for Measurement Control and Laboratory Use.
- **The Electromagnetic Compatibility Regulations 2016 (SI 2016 / 1091) as amended.**
BS61326-1:2013 Electrical Equipment for Measurement , Control and Laboratory Use - EMC Requirements.
- **The Restriction of the Use of Certain Hazardous Substances in Electrical and Electronic Equipment Regulations 2012 (SI 2012 / 3032) as amended.**

Signed for and on behalf of Peak Scientific by

Signed: 

Name: Fraser Dunn

Position: Design Engineering Manager
Peak Scientific Instruments Ltd,
Inchinnan, Renfrew, Scotland, PA4 9RE, UK.

Date: 7th October 2021



CSA Compliance Statement

CSA Group (Canadian Standards Authority) is a Nationally Recognised Testing Laboratory (NRTL), headquartered in Toronto Canada.

They are authorised to evaluate product to both their own and Underwriters Laboratory (UL) standards and certify the product to be in compliance to the relevant standards.

Peak products are certified to the current in force revision of the following standards in order to cover both Canadian and United States requirements for “Safety Requirements for Electrical Equipment for Measurement, Control and Laboratory use, Part 1: general Requirements”.

Canada: CAN/CSA C22.2 No 61010-1-12

United States: UL 61010-1

As a result the products covered by this statement are certified and listed by CSA accordingly and are entitled to carry the CSA mark with both Canadian and United States subscripts , as shown below on the product rating label.



WEEE Compliance Statement

The Waste Electrical and Electronic Equipment (WEEE) Regulations SI 2013 No 3113 and or the Waste Electrical and Electronic Equipment (WEEE) Directive 2012/19/EU apply to all electrical and electronic equipment placed on the market in the UK and EU covered by the scope of regulations which can be found in the Government Guidance Notes (PDF) produced by the Department for Business Innovation and skills for the UK and here for Europe.

All PEAK products that are subject to the WEEE directive are compliant with the WEEE marking requirement. Such products are marked with the “crossed-out wheellie bin” symbol (shown below) in accordance with European standard EN50419. All old electrical equipment can be recycled. Please do not dispose of any electrical equipment (including those marked with this symbol) in general rubbish bins. Please contact your dealer or distributor for clarity.



Warranties and Liabilities

1. The Company warrants that it has title to the Goods.
2. Subject to the provisions of this clause the Company warrants that the Goods shall comply in all material respects with any specification referred to in the Order Confirmation (as the same may be amended) and shall, subject thereto, be free from defects in material and workmanship for the lesser of a period of twenty-four months from the date of delivery or twenty-five months from the date of dispatch from the factory. The 24m warranty is conditional on completion of replacement of the de-ionizer cartridge every 12 months from the date of first use of the generator and use of the correct grade of deionized water (ASTM type II, <1 µS/cm conductivity / >1 Mff-cm resistivity). Failure to change the de-ionizer cartridge and supply the correct grade of de-ionized water will render the 24 month warranty null and void.
3. Save as provided in this clause and except where the Goods are sold to a person dealing as a consumer (within the meaning of the Unfair Contract Terms Act 1977) all warranties, conditions or other terms implied by statute or common law are hereby expressly excluded save to the extent they may not be lawfully excluded. When the Goods are sold to a consumer within the meaning of the Unfair Contract Terms Act 1977 their statutory rights are not affected by the provisions of this clause.
4. In the event of the Customer making a claim in respect of any defect in terms of clause 2 hereof the Customer must.
 1. Reasonably satisfy the Company that the Goods have been properly installed, commissioned, stored, serviced and used and without prejudice to the generality of the foregoing that any defect is not the direct or indirect result of lack of repair and/or servicing, incorrect repair and/or servicing, use of wrong materials and/or incorrect spare parts
 2. Allow the company to inspect the Goods and/or any installation and any relevant packaging as and when reasonably required by the Company.
5. Subject to the Company being notified of any defect as is referred to in sub-clause 2 hereof within a reasonable time of it becoming apparent and subject always to the terms of sub-clause 3 hereof, the Company shall, in its option, replace or repair the defective Goods or refund a proportionate part of the Price. The Company shall have no further liability to the Customer (save as mentioned in sub-clause 4 hereof).
6. The Company shall be liable to indemnify the Customer in respect of any claim for death or personal injury to any person in so far as such is attributable to the negligence or breach of duty of the Company or any failure by the Company to comply with the provisions of sub-clause 2 hereof.
7. Save as provided in sub-clause 2 hereof the Company shall not be liable in respect of any claim by the Customer for costs, damages, loss or expenses (whether direct, indirect, consequential or otherwise) or indemnity in any respect howsoever arising including, but not by way of limitation, liability arising in negligence (other than pursuant to clause 5 above) that may be suffered by the Customer or any third party.

Technical Specification

Precision Hydrogen SL

Environment

	100 cc	200 cc
Minimum Operating Ambient Temperature	10°C (50°F)	
Maximum Operating Ambient Temperature	35°C (95°F)	
Maximum Altitude	3000 m	
Maximum Relative Humidity	90% Non-Condensing	
Minimum Storage Temperature*	10°C (50°F)	
Maximum Storage Temperature*	25°C (77°F)	

Generator Outlets

Max Flow Rate	100 cc/min	200 cc/min
Purity	99.9995%	
Gas outlet	1 x 1/8" Swagelok compression fitting	
Delivery pressure	100 psi (6.9 bar)	

Electrical Requirements

Voltage	100-240VAC +/-10%	
Frequency	50/60 Hz	
Current	6A Max.	
Input Connection	C14 Connection	
Power Cord (Supplied)	C13 socket to local connection (10A minimum)	
Pollution Degree	2	
Installation / Over Voltage Category	II	

General

Generator Dimensions cm	16.0 (6.3") x 38.5 (15.2") x 25.0 (9.8")	
Generator Weight	8 kg (17.6 lbs)	
Shipping Crate Dimensions cm	73 (28.7") x 52 (20.5") x 37 (14.6")	
Shipping Weight	23.2 kg (51.1 lbs)	
Heat Output	983 BTU / Hr	
Water Purity Requirement	ASTM Type II (<1 µS/cm / >1 MΩ-cm)	

* When taken out of storage the Generator should be allowed to acclimatize at room temperature for a minimum of 3 hours before operation.

Introduction

Precision Hydrogen SL has been developed to provide a source of high purity hydrogen gas, suitable for GC detector gas supply.

Features include:

- Easy to use single button interface
- Status indicative lighting feature
- Purities of up to 99.9995%

Precision Hydrogen SL is based on proven technology, producing hydrogen by electrolysis using a Proton Exchange Membrane (PEM) cell. Moisture removal is achieved by a two-stage patented Nafion technology and dessiccant drying.

To ensure this generator model meets our high expectations with regards to reliability and performance, we have tested this model extensively at our manufacturing plant and in the field to ensure reliability and longevity of the system.

Principle of Operation

The Peak Scientific hydrogen generator produces high purity hydrogen gas, H₂. Hydrogen does not occur naturally on earth and must be formed via the decomposition of other molecules, in this case via the splitting of water molecules into hydrogen and oxygen in a process known as electrolysis.

The electrolyser used in the Peak Scientific hydrogen generator is known as a Proton Exchange Membrane (PEM) electrolyser. This type of electrolyser was first described in the mid-1960's by General Electric as a method for producing oxygen for the Gemini space program. PEM electrolysis has been continually developed since its introduction and has remained the state-of-the-art technology for water electrolysis and the production of high purity hydrogen ever since.

The most important element of the generator is the electrolyser cell where the electrolysis reaction takes place. This consists of two electrodes (an anode and a cathode), which are separated by the proton exchange membrane which gives the technology its name. During operation deionised water is fed to the anode of the electrolysis cell where it is split into oxygen, protons and electrons with the aid of a precious metal catalyst. The oxygen is vented to atmosphere from the generator. The protons travel across the membrane and simultaneously the electrons travel around the external electrical circuit. These protons and electrons then recombine at the cathode of the electrolyser, again with the aid of a precious metal catalyst to produce the hydrogen gas. The high purity of the hydrogen is assured by the membrane which completely separates the hydrogen produced at the cathode from the oxygen being produced at the anode. These processes are described by the following equations:

Anode Reaction

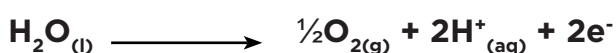

Cathode Reaction



Deionised water is critical to the operation of the system and must have a purity of ASTM Type II or better to prevent damage to the membrane. Failure to use this grade of deionised water will invalidate the 2 year warranty of your generator. The water is automatically loaded (either at power up or periodically during operation) and the rate at which the water is consumed depends on the amount of hydrogen being produced.

A small amount of the electrical energy input is lost as heat and this is removed from the generator by the ventilation system.

The Peak Scientific hydrogen generator generates hydrogen on demand. By maintaining the pre-set pressure and using this as a reference value, the generator will produce the precise amount of hydrogen required. As soon as the demand ceases, no further hydrogen will be sent to the user's application. During this time bubbles may still be observed in the water tank. This is due to the generator maintaining its internal pressure and ensuring that clean, dry hydrogen is available immediately on demand when the user requires it.

Unpacking

Although Peak Scientific takes every precaution with safe transit and packaging, it is advisable to fully inspect the unit for any sign of transit damage.

Any damage should be reported immediately to the carrier and Peak Scientific or the Peak Partner from where the unit was purchased.

Follow the unpacking instructions posted on the side of the crate.

Please save the product packaging for storage or future shipment of the generator.

The generator is safe to be unpacked by one person providing safe lifting practices are employed.

Note: Included with the Generator is a "Fittings Kit" containing mains power leads for UK, EU & US and also all the required fittings and warranty registration card. Please use only the power cords supplied, or a correctly rated power cord suitable for mains connection. Be careful not to discard the contents of the fittings kit.

Fittings Kit Contents

Supplied in the Fittings Kit are all the fittings required to connect the generator to the application. The contents of the Fittings Kit are as follows:

1. Tygon Tubing*		x 1m
2. Barbed Hose Fitting*		x 1
3. In-line Water Filter**		x 1
4. UK Mains Power Cable		x 1
5. EU Mains Power Cable		x 1
6. US Mains Power Cable 110V	x 1	
7. US Mains Power Cable 230V		x 1
8. Installation Guide- Precision Hydrogen		x 1
9. 4 Litre Water Bottle***		x 1
10. A5 simple user maintenance guide		x 1
11. Desiccant Cartridges	x 2 (1 to be installed prior to first use of generator) (100cc) x 4 (1 to be installed prior to first use of generator) (200cc)	
12. DI cartridge	x1 (to be installed prior to first use generator)	

* supplied with all models

** supplied with automatic and pressure fill models

*** optional extra for models with automatic fill

All of the generator output ports are located on the output panel at the rear of the generator.

Installation

Location

The generator should be located on a flat, level surface for operation - this will ensure that the water level sensors within the unit operate correctly. Some components in the generator produce heat during operation and therefore an adequate airflow must be maintained around the generator to allow the ventilation system to perform efficiently.

If the generator is stored in an enclosed space the environment must be controlled via an air conditioner or extraction fan. The provision must be made to allow the volume of air in the room to be changed 5 times per hour. The risk with hydrogen is a leak into the environment raising the hydrogen content to the explosive limit. The rear of the generator will become warm to the touch during operation - a minimum clearance of 15 cm (6") from other bodies is recommended.

Do not obstruct or connect the vents to any application. Failing to observe this could lead to permanent damage of the generator.

Do not expose the unit to freezing conditions. Please adhere to the operating temperatures below:

Do not position the equipment so that it is difficult to disconnect the mains plug.

Minimum Operating Ambient Temperature: 10 °C (50 °F)

Maximum Operating Ambient Temperature: 35 °C (95 °F)

Generator Overview

General Dimensions

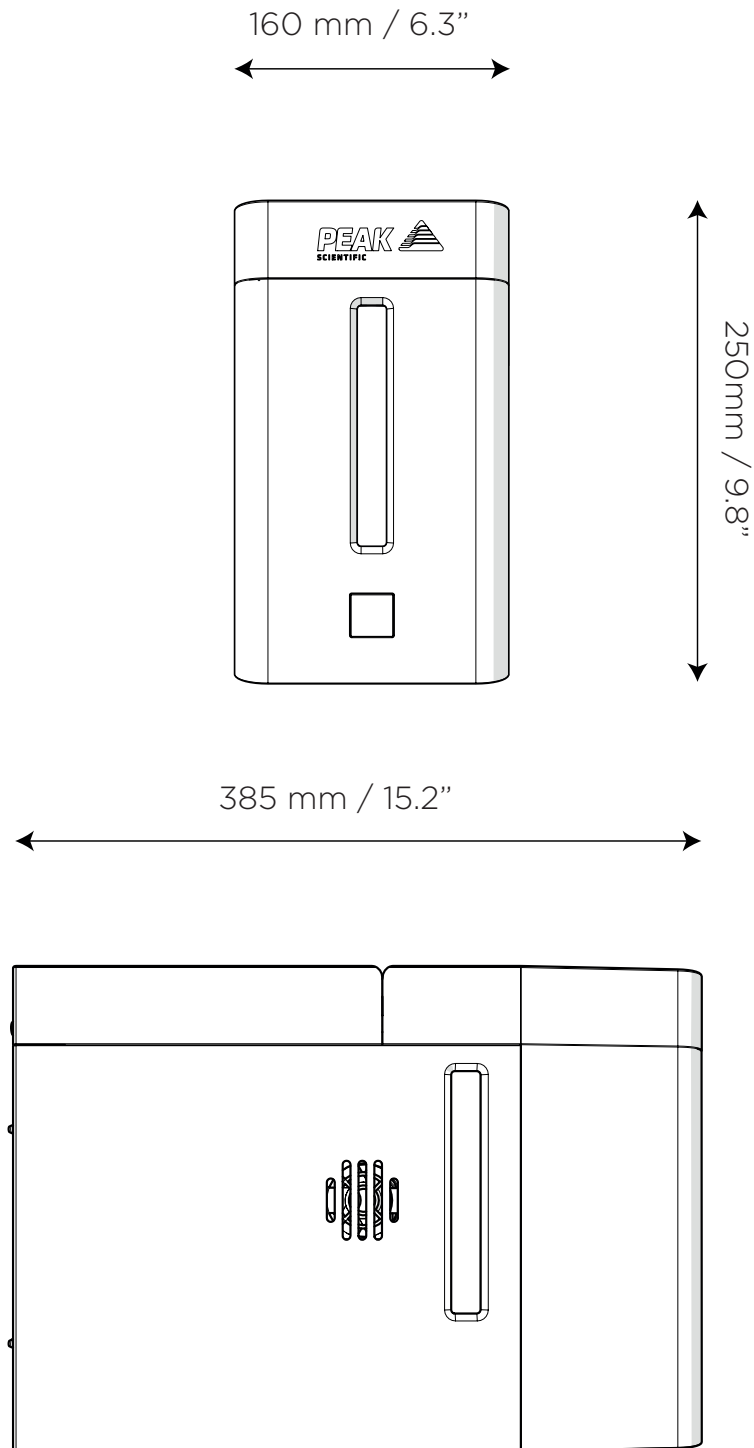

The Generator must always be placed on a flat, level surface. Failure to do so will affect the performance of the Generator.

Unit Controls

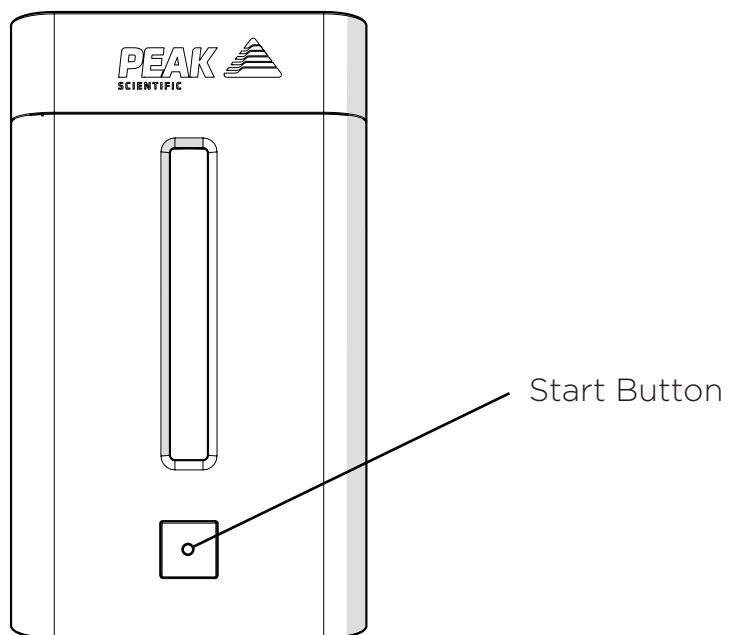

Rear Connections

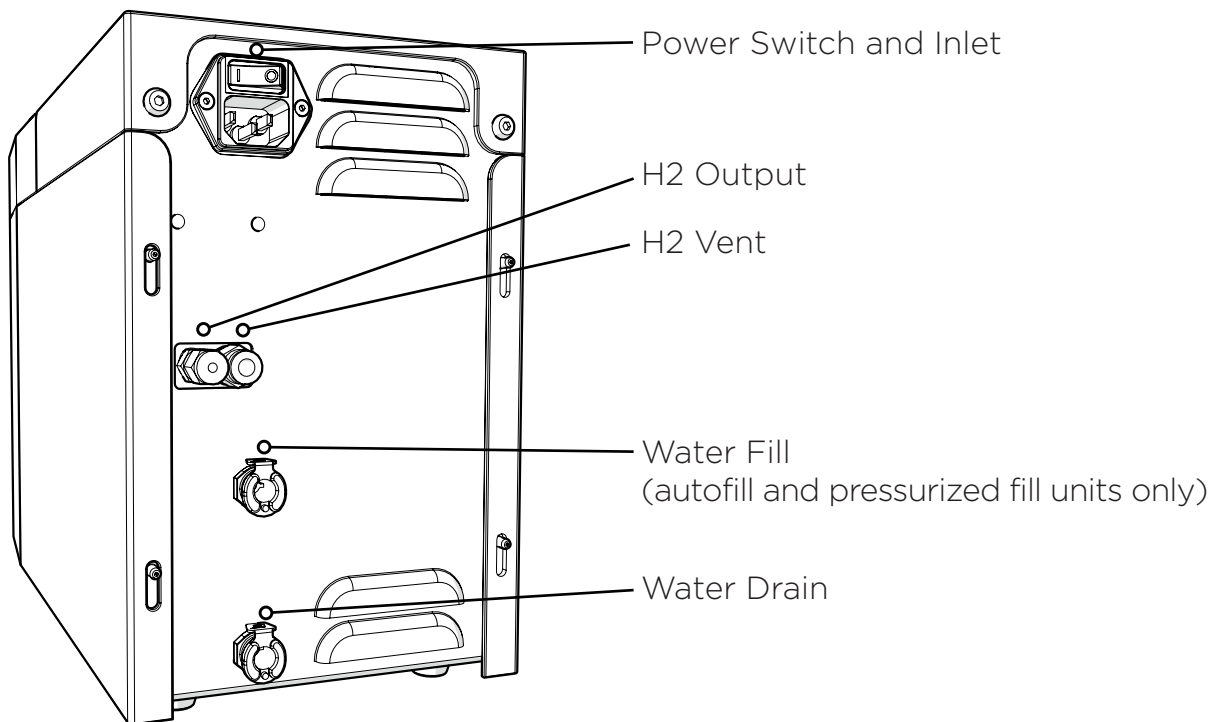



Ensure all inlets and outlets are connected to correct sources and applications



All connections should only be made by personnel who are technically competent to do so



Generator must be switched off and unplugged prior to any cleaning or maintenance operations

Tubing

For the hydrogen supply line, it is recommended that only clean grade copper or stainless steel tubing should be used.

Plastic tubing material such as Teflon®, polyvinyl chloride, or Tygon® should not be used when plumbing GCs since these materials will allow air and water to diffuse into the gas lines. In addition, plastic tubing can give off organic impurities which can cause ghost peaks and baseline instability.

Furthermore Peak Scientific recommend that compression fittings are used, and that the fittings are free from Teflon® tape.

H2 Ventilation

Peak Scientific recommends that the H2 Exhaust port at the rear of the unit should be connected to an exhaust hood, or other ventilation system, to ensure safe disposal of vented gasses. Tubing sizes for the vent port are 6mm OD.

Water Quality

Use only High Grade Deionised water, which must have a conductivity of less than or equal to $1\mu\text{S}/\text{cm}$ ($>1\text{ Mff-cm}$) @ 20°C and should be replaced as required. Water quality should be checked prior to being used to supply the Precision Hydrogen Generator.

Use of water in the Precision Hydrogen Generator with a purity not specified above will result in a reduced efficiency of hydrogen production, failure of the generator and loss of warranty.

Water should be stored in a UV protected dark container away from direct sunlight. The bottle should have a vented lid to minimise any dust or debris contaminating the water supply. A suitable external water bottle is available from Peak Scientific.

Note: Customers should check the water quality of the external water supply once a week to maintain the health of the generator.

Manual Water Tank Filling

The generator must be filled with DI water to be functional. For manual fill systems, follow the below steps.

1. Lift the hinged lid back, then remove the tank cover.

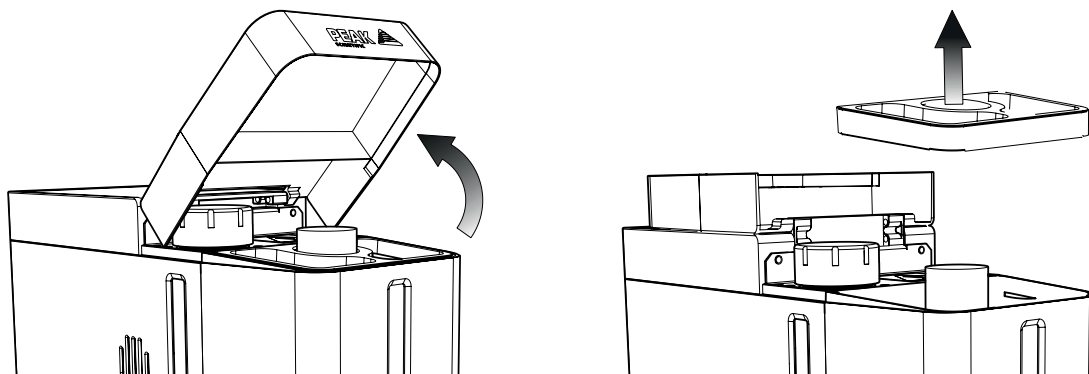

2. Fill the water tank from your lab's supply of DI water, and ensure the tank cover is replaced, afterwards.

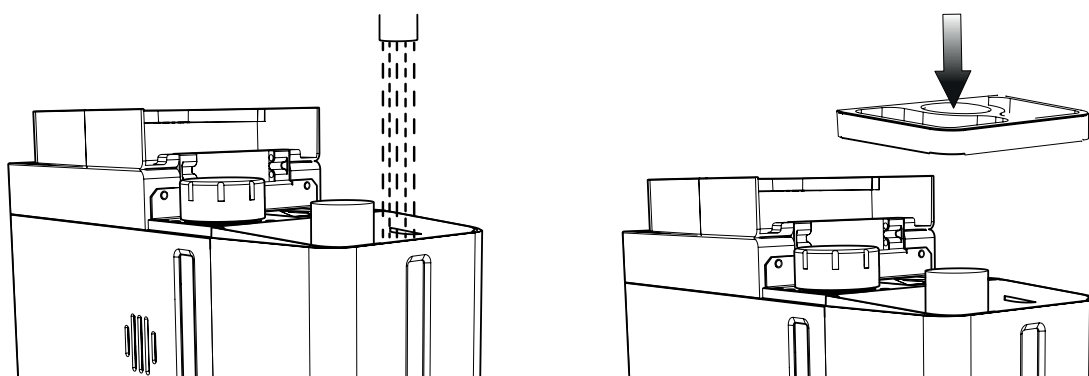

3. Close the hinged lid.

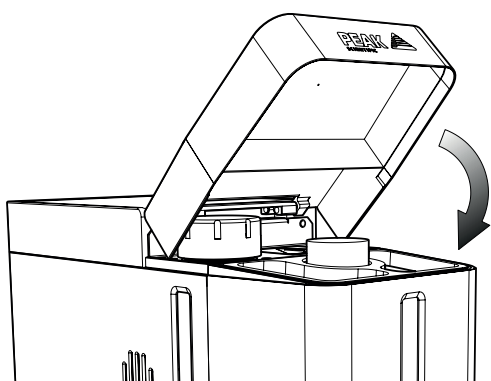

Automatic Filling (Automatic Fill Upgrade units only)

The Precision Hydrogen generator uses an automatic water filling system as an optional upgrade, whereby sensors in the unit's internal water tank detect when the water level reaches a minimum.

This then refills the tank using a rear connection to an external DI water supply.

The unit should be connected to the water supply as shown below.

Using the length of FEP tubing and the hose barb fitting from the fittings kit, attach the barb to the tubing. Then connect one end to the water supply and the other to the Fill port at the rear of the Precision Hydrogen.

For efficient water filling the external supply should be no more than 2 metres away from the connection on the generator.



WARNING

The DI Water Supply source **MUST NOT** be located higher than the height of the surface that the Precision Hydrogen generator is placed upon. A supply located higher than specified will result in the generator's internal water bottle over filling.



WARNING

A pressurized DI Water Supply Source may only be used if the Pressurized Water Feed optional upgrade is purchased.

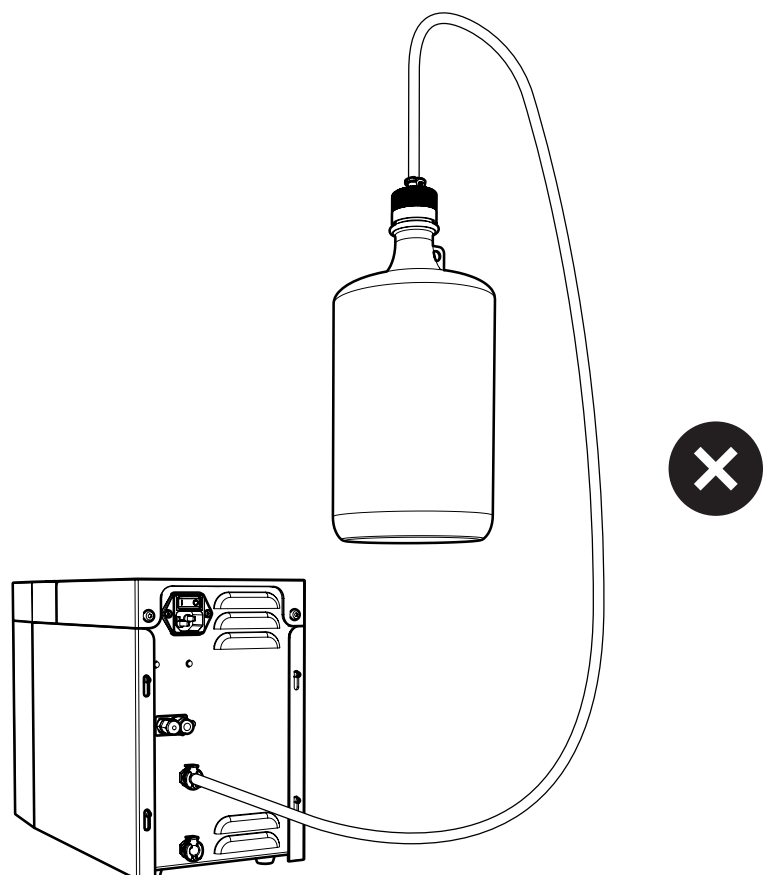
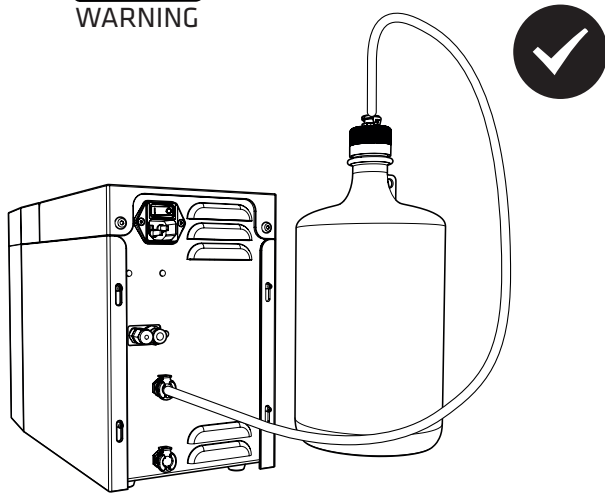

Due to normal setting and performance tolerances, the settled level at which water fill stops may vary from generator to generator. If the generator cannot load enough water to switch the sensors in the water bottle the generator will illuminate amber and cease generating hydrogen until the fault has been resolved.

To resolve this, check your external supply before cycling the power on the generator. Once the low level water sensor disengages the generator will then begin producing hydrogen as before.

Four and eight litre water storage bottles can be purchased from Peak Scientific, please contact your Sales Representative for more information.

Pressurized Filling (Automatic Fill Upgrade units only)

A pressurized feed option is available as a valve fitted to the fill inlet, instead of the load pump and can be supplied by 1-3 bar pressurized water feed.

Note: No more than 3Bar pressure is allowed.

Inline Water Filter Cleaning (Automatic Fill Upgrade units only)

The in-line water filter can be cleaned by running fresh deionised water backwards through it.

1. Remove filter from back of generator and rotate to reverse the orientation.
2. Connect the tubing and fitting to the side of the filter which was previously connected to the generator's fill port.
3. Run fresh deionised water through the filter, then reattach to the back of the generator.

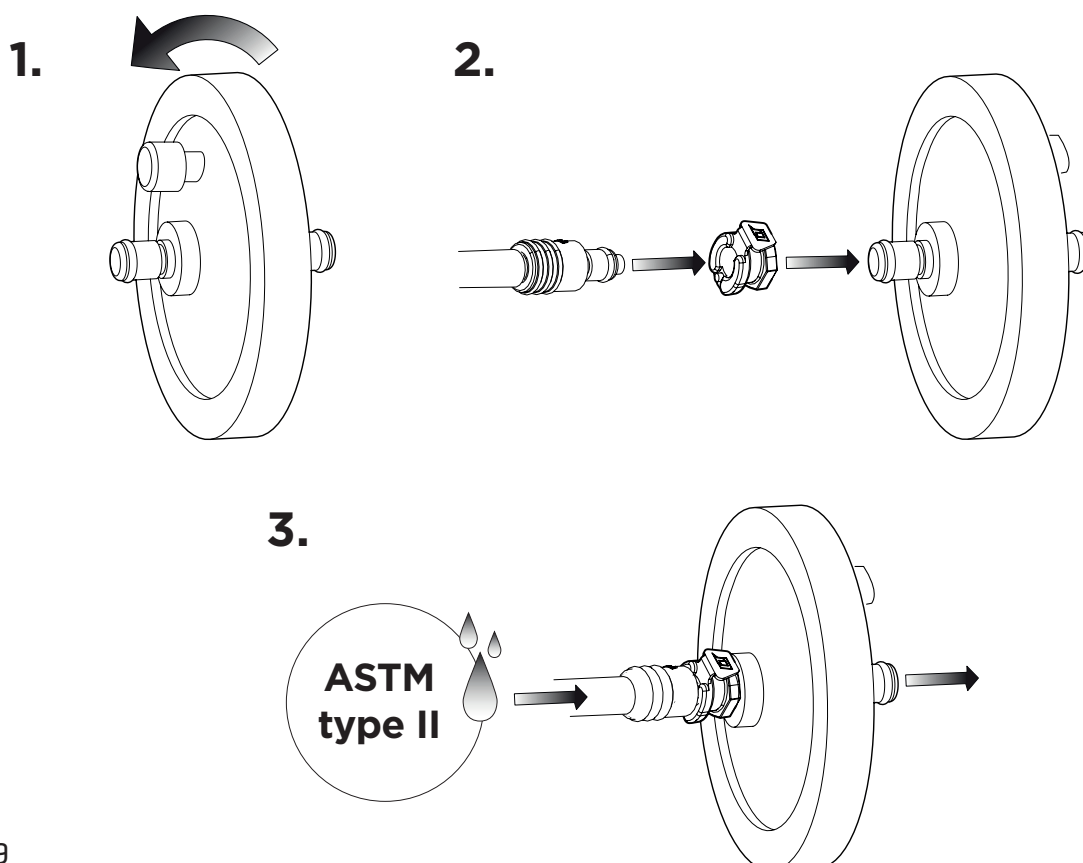

Water Usage

The water consumption rate of the Precision Hydrogen Generator is completely dependent on the rate at which the hydrogen is produced.

The graphs below show an estimation of the water consumption from the generator in Stand-by mode through to maximum Hydrogen output.

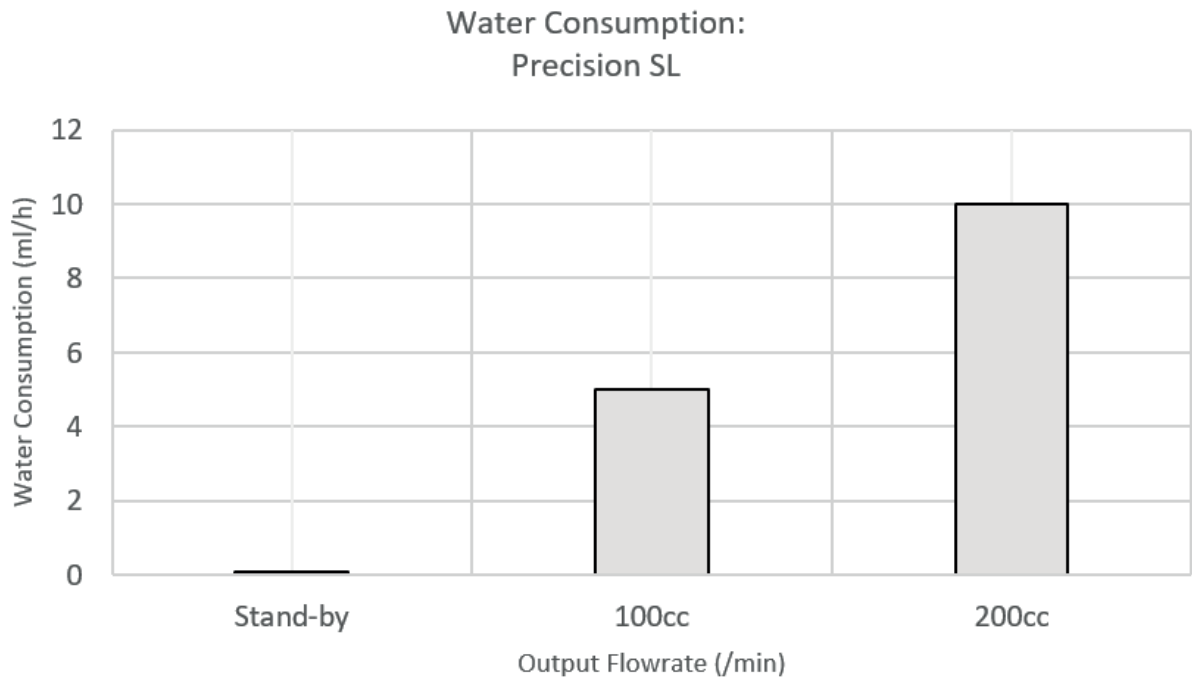

Electrical Connection

Connect the generator into an appropriate electricity supply, between 100-240VAC. Refer to the generator serial plate for input specification and ensure your supply matches the requirements.

If the appropriate power cord is not supplied; a new CSA, UL approved power cord, rated to at least 10 amps, can be fitted by a qualified electrician. If a substitute main supply cord is used, ensure that it has adequate ratings and appropriate approvals for the country of operation. Failure to do so could cause damage to the generator or risk of overloading of the power cord.



This unit is classified as SAFETY CLASS 1. THIS UNIT MUST BE EARTHED. Before connecting the unit to the mains supply, please check the information on the serial plate. The mains supply must be of the stated AC voltage and frequency.

EARTH/GROUND (E):-	Green & Yellow	or	Green
LIVE (L):-	Brown	or	Black
Neutral (N):-	Blue	or	White

Start-up Sequence

CHECK:

1. H₂ Outlet is connected to application
2. Mains power is connected

Turn the power switch ON. The water tank will light up, the cooling fan will rotate and the generator will exhaust any stored hydrogen.

On power up the generator will check the water level, once the water level is at the minimum level required the generator will perform a diagnostic check including a leak test, this should take approximately six minutes and during this time the tank illumination will cycle from dim to bright

Upon successful completion of the leak test, the tank illumination will turn solid green and the generator is ready to deliver hydrogen.

Once the generator is at pressure, the delivery valve may be toggled by momentarily pressing the front button. Bubbles will be visible through the viewing window when the generator is producing hydrogen. At low output flows bubbles may be intermittent as the electrolysis cell control modulates to maintain system pressure.

The generator may be restored to a depressurized state by pressing and holding the front button for at least three seconds. This will cause the generator to cease hydrogen production, illuminate the water tank blue, and exhaust any stored hydrogen through the exhaust port at the rear of the generator.

Note: If leak test is unsuccessful, the water tank will illuminate amber and the generator will cease attempting to produce hydrogen. The user should contact their Peak service provider.

Liquid Leak Detectors

Liquid leak detectors should not be used on the Precision Hydrogen. These solutions are easily drawn into the high purity hydrogen gas system and can cause contamination of the system. If a liquid solution has to be used, then it should be IPA based, or a portable hydrogen detector should be used.

Gas Traps

It is recommended to follow the best practice advice from your instrument manufacturer. For hydrogen supplied to GC detectors, a hydrocarbon trap is normally recommended, however, hydrogen produced by Precision Hydrogen generators is hydrocarbon-free and hydrocarbon traps should not be necessary.

Switching the Unit Off

The unit can be switched off at any time using the following procedure.

The generator may be restored to a depressurized state by pressing and holding the front button for at least three seconds. This will cause the generator to cease hydrogen production, illuminate the water tank blue, and exhaust any stored hydrogen through the exhaust port at the rear of the generator. The generator may then be switched off by the power switch on the rear panel.

Cleaning

Clean the outside of the generator, using only warm soapy water and a clean damp cloth. Ensure the cloth is thoroughly rung out to remove excess fluid prior to use.



Cleaning should only be undertaken with the power switched off and the power cord removed from the rear of the Generator.



CAUTION

Under no circumstances should any solvents or abrasive cleaning solutions be used as these can contain fumes that could be harmful to the Generator and lab personnel.

Water tank should be cleaned as a minimum on an annual basis in line with instructions given in step 2 of the DI cartridge change instructions.

For automatic and pressure fill models, the inline water filter may be cleaned by removing from the rear of the generator and running clean deionised water backwards through the filter.

De-ionizer cartridge Replacement

DI cartridge requires an annual change, although it should also be changed if the water supply is contaminated with water of a conductivity above the specified limit. Replacement of the DI column (the column in the middle of the water tank) is by rotating 90° anti-clockwise then pulling up and out of the tank. The new cartridge is put in by lowering into the recess and twisting 90° clockwise to lock in position. **Please ensure that the DI cartridge is fully wet before it is installed.**

1. **Depressurise the generator and disconnect power.** To replace the DI cartridge, lift the hinged lid back, then remove the de-ionizer column by turning 90° anticlockwise and pulling upwards..

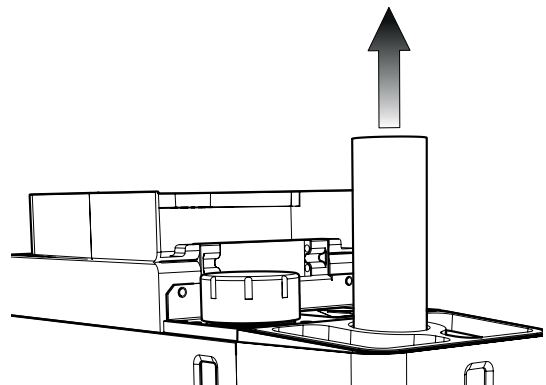
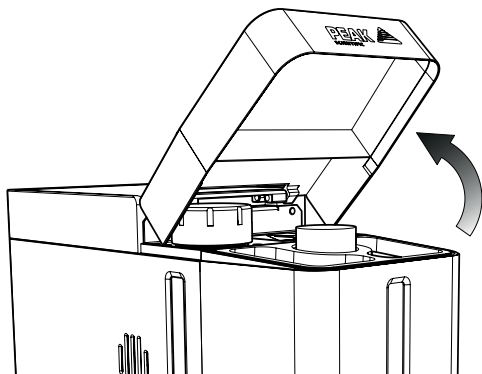

2. Drain the tank using the drain port on the rear of the generator. Once tank is empty, wipe down with a clean, lint-free cloth.
3. Lower the new DI cartridge into the recess and rotate 90° clockwise to lock in position, then close the lid.

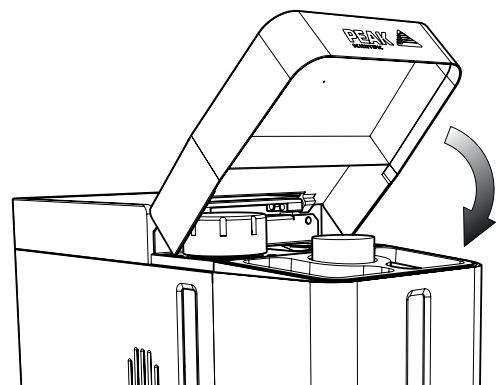
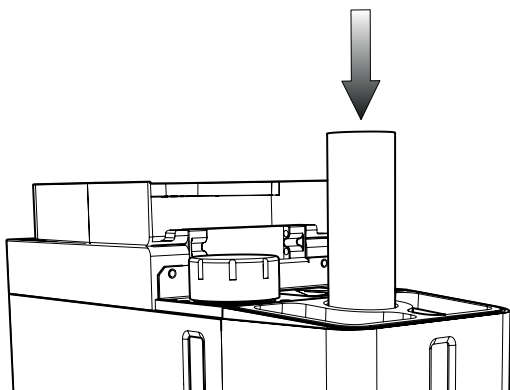

4. The unit can now be re-filled with water and switched on.

Replacement of Desiccant Capsule

The desiccant capsule has a minimum expected life of 12 weeks. The capsule consists of molecular sieve interspersed with silica gel, viewable through the window on the side of the generator. The capsule should be replaced when all of the silica gel has visibly darkened.

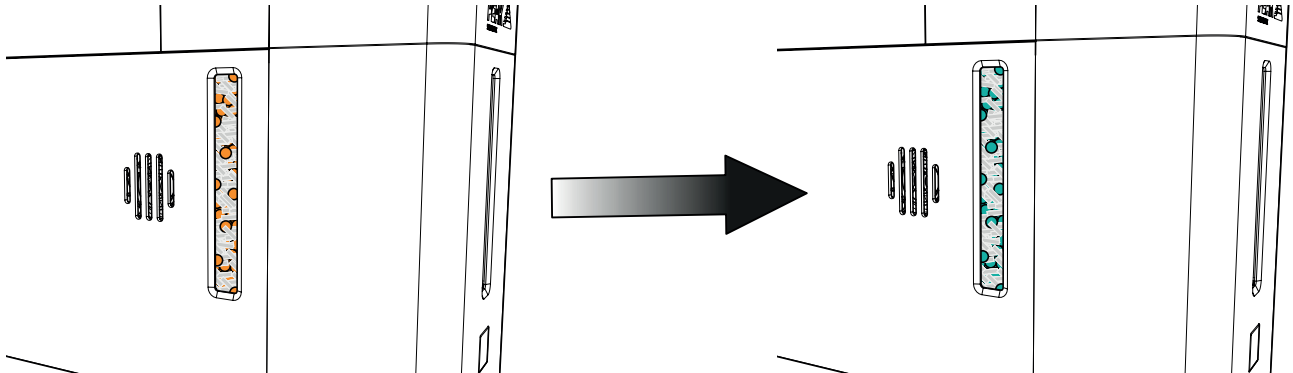

1. To replace the capsule, **depressurise the generator and disconnect power.** Lift the hinged lid back, then unscrew the capsule cap anticlockwise to remove.



Be careful to avoid injury when unscrewing the capsule cap.

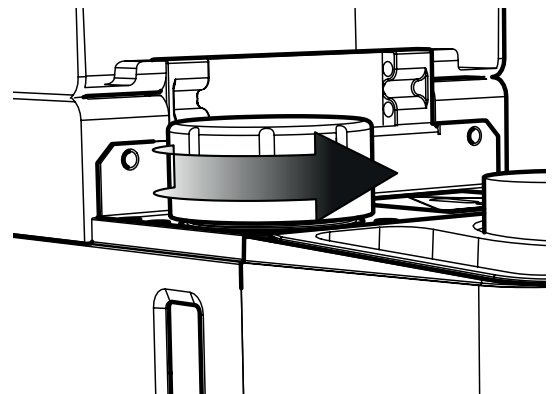
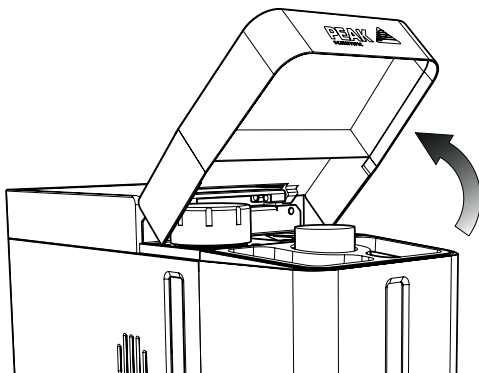

2. Next withdraw the inner tube and dispose as per your company's hazardous waste disposal policy and MSDS guidelines. The new capsule may now be inserted into the outer collar.

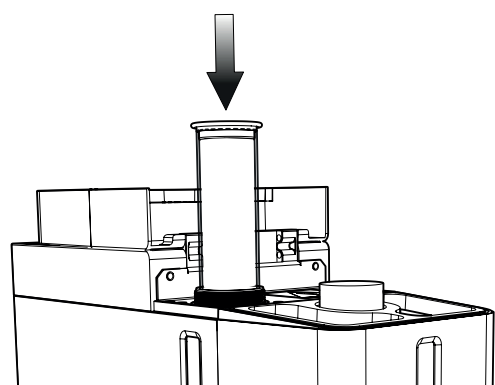
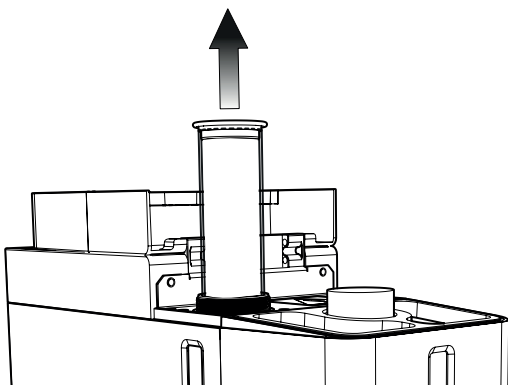

3. The cap can then be replaced ensuring not to over-tighten the cap and the hinged lid can be closed.

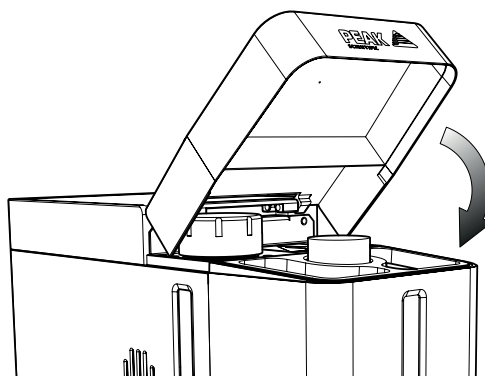
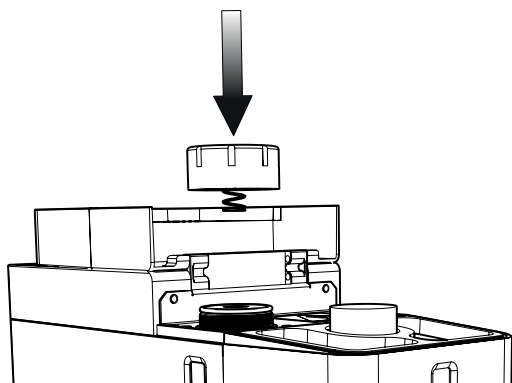

4. The unit can now be switched on.

Service Requirements

Service Schedule

Purchase Interval	Component	Visit
12 Months	Precision Hydrogen SL 100cc 12 Month Kit	www.peakscientific.com/ordering
	Precision Hydrogen SL 200cc 12 Month Kit	

Note: Only Peak approved components should be used.

Service Plans



Peak Scientific offer two service plans. The Complete Service Plan, specifically designed for generators operated in critical environments, also includes full breakdown cover, guaranteed response times and generator upgrades if available. Our Standard Service Plan, covering the basic needs of our generators, features special deals on spare parts and breakdowns.

If you want to know more about our Service Plan options and how we ensure that your instrument can run with the maximum uptime and performance, please contact us at maintenance@peakscientific.com

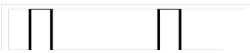

General Troubleshooting

Problem	Possible Solution
The generator will not switch on.	<ul style="list-style-type: none"> • Ensure power cord is plugged into the Generator and that the power socket is turned on. • Ensure generator is switch on at rear of generator • Check the fuse in the power cord plug, if fitted. • Contact your service provider 
The generator has power, but the water tank is not illuminated, and no hydrogen is produced	<ul style="list-style-type: none"> • Contact your service provider.
The generator is not producing hydrogen	<ul style="list-style-type: none"> • Contact your service provider.

Overview of LED Colour States

LED Colour State	Fault
Pulsing green	<ul style="list-style-type: none"> • Building pressure (start-up test)
Solid green (dim)	<ul style="list-style-type: none"> • At pressure, in standby
Solid green (bright)	<ul style="list-style-type: none"> • At pressure, delivery valve open
Pulsing green / yellow	<ul style="list-style-type: none"> • Delivery valve open, pressure low
Pulsing blue	<ul style="list-style-type: none"> • Depressurising
Solid blue	<ul style="list-style-type: none"> • Depressurised
Solid purple	<ul style="list-style-type: none"> • Separation tank fault
Pulsing purple 	<ul style="list-style-type: none"> • Hardware communication fault
Pulsing purple 	<ul style="list-style-type: none"> • Pressure transducer fault
Solid amber (immediately on power-on)	<ul style="list-style-type: none"> • Overpressure
Solid amber (during start-up test)	<ul style="list-style-type: none"> • Start-up test failed
Pulsing amber	<ul style="list-style-type: none"> • Water critical • Water feed fault • Capacity Excess (generator fails to maintain flow)

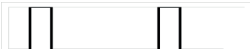
Debugging by LED

LED Colour State	Fault	
Solid purple	Separation tank fault	<ul style="list-style-type: none"> Power cycle generator If fault persists, contact your service provider
Pulsing purple 	Hardware communication fault	<ul style="list-style-type: none"> Contact your service provider
Pulsing purple 	Pressure transducer fault	<ul style="list-style-type: none"> Contact your service provider
Solid amber (immediately on power-on)	Overpressure	<ul style="list-style-type: none"> Contact your service provider
Solid amber (during start-up test)	Start-up test failed	<ul style="list-style-type: none"> Ensure dryer cap has been securely replaced (see section “Replacement of Desiccant Capsule”) Check water quality and ensure DI column has been replaced within annual schedule Contact your service provider
Pulsing amber	<ul style="list-style-type: none"> Water critical 	<ul style="list-style-type: none"> Ensure water tank fill level is within sight glass window on front of generator Contact your service provider
	<ul style="list-style-type: none"> Water feed fault 	<ul style="list-style-type: none"> Ensure external water source is connected Contact your service provider
	<ul style="list-style-type: none"> Capacity Excess (generator fails to maintain flow) 	<ul style="list-style-type: none"> Check that demand is within the system’s maximum rated flow Ensure there are no leaks between generator and application Check water quality and ensure DI column has been replaced within annual schedule Contact your service provider

Go Online or Complete and Return

You can register for your **FREE 12 month Warranty** with ease online at www.peakscientific.com/protected.

Alternatively, you can send the completed form to Peak Scientific by post or email at warranty@peakscientific.com.

Go Online or Complete and Return

You can register for your **FREE 12 month Warranty** with ease online at www.peakscientific.com/protected.

Alternatively, you can send the completed form to Peak Scientific by post or email at warranty@peakscientific.com.

Product Warranty Registration			
Contact name			
Email address			
Company			
Address			
City/town			
Postcode			
Country			
Telephone			
Generator serial #			
Model type			
Installation date			
Do you still use an alternative gas solution i.e. cylinders or bulk liquid?	Yes	No	
What gas requirements do you have in your lab?	Hydrogen	Nitrogen	Zero Air

Extend your cover with

Peak Scientific offer comprehensive gas generator after sales support packages. Peak [Protected] aftercare support can guarantee an on-site response within 72 hours*, genuine parts from our ISO9001 approved factory and a 90% first-time fix rate. See our enclosed Peak [Protected] leaflet for further information.

Important!

You have 1 month to register your Peak Scientific product from the date of installation. Once registered the warranty will be honoured for a period of 12 months. If you wish to defer the installation of your generator, you must notify Peak Scientific immediately by emailing warranty@peakscientific.com. For generators that remain unregistered after 1 month from the shipment date, the warranty will be considered active from the date of factory dispatch.

* Complete Plan only

Important!

You have **1 month to register** your Peak Scientific product from the date of installation. Once registered the warranty will be honoured for a period of 12 months. If you wish to defer the installation of your generator, you must notify Peak Scientific immediately by emailing warranty@peakscientific.com. For generators that remain unregistered after 1 month from the shipment date, the warranty will be considered active from the date of factory dispatch.

[**PEAK Protected**]TM

Peak Scientific has highly trained, fully certified Field Service Engineers located in over 20 countries across every continent around the world. This allows us to provide an industry-leading rapid response service to our customers. With **[Peak Protected]**, your laboratory's productivity becomes our top priority.

To discuss Peak Protected generator cover and payment options speak to your local Peak Representative or for further information contact: protected@peakscientific.com

Peak Scientific

Fountain Crescent
Inchinnan Business Park
Inchinnan
PA4 9RE
Scotland, UK

Tel: +44 141 812 8100

Fax: +44 141 812 8200

For further information on any of our generator products please contact marketing@peakscientific.com